

Custom Pig Tray

16" & Above (406.5mm & Up)

Apache's Custom Pig Trays are not only for displaying our industry leading cleaning tools, the pig tray provides assistance with transportation, storage and during maintenance operations in the field when launching and receiving your cleaning tool through the pipeline.

Featuring an all-aluminum frame, the construction of each tray is based on customer specifications and optimized by Apache's in house Engineering department. Apache's custom pig trays are available with a plethora of options and customizable details!

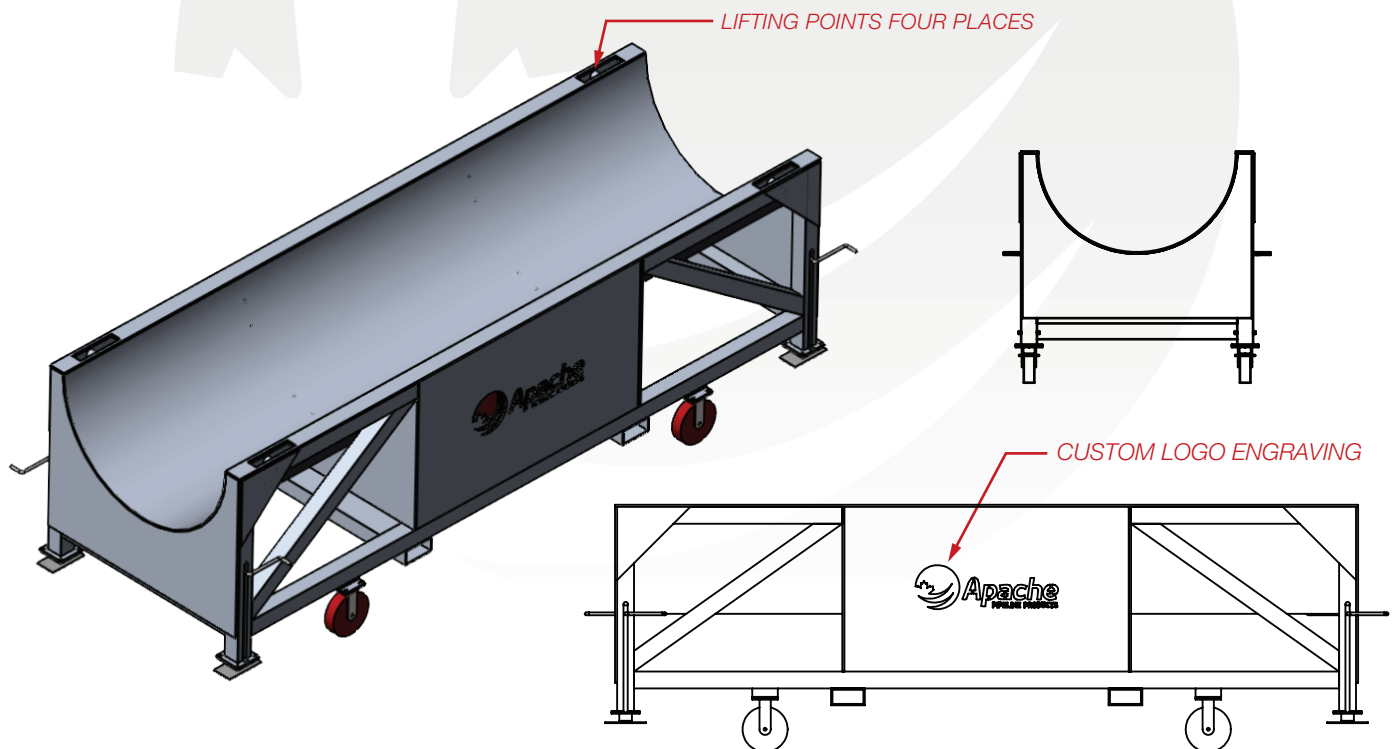

Features & Benefits:

- Equipped with completely adjustable steel legs to suit your maintenance operation's &/or storage's location.
- Custom length's based on dimensions of cleaning &/or inspection tool(s).
- Certified for lifting as per **ASME B30.20**.
- All aluminum frame is lightweight and non-sparking.

Options Available:

- Forklift sleeves (aluminum).
- Company Name &/or Logo engraved onto front of tray.