

B A T C H I N G

XF

3-14" (76-356mm)

The Series XF is primarily used for batching dissimilar fluids.

With its standard three cup-three sealing disc design, the XF pig provides a positive seal between fluid interfaces for efficient batching and separating. It is typically used for longer distance operations.

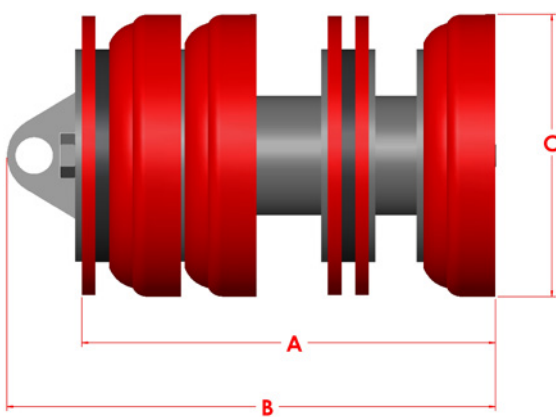

Size	A	B	C	Weight	Part #
3"	7.625	9.000	3.375	3.0	70-6786-03
4"	8.250	9.000	4.375	6.0	70-6786-04
6"	10.250	12.500	6.375	18	70-6786-06
8"	12.000	14.375	8.500	33	70-6786-08
10"	15.125	18.000	10.625	58	70-6786-10
12"	18.125	20.875	12.750	82	70-6786-12
14"	20.750	23.500	13.875	92	70-6786-14

Features & Benefits:

- Every Series XF pig is equipped with Apache Series C cups. As with all of Apache products, the Series C cup and discs were specifically developed to perform efficiently and reliably.
- To maximize durability, all discs are made from Reliathane, Apache's special blend of wear-resistant polyurethane.
- The large wearing surface of the cup promotes longer life, while product pressure holds the cutting edge firmly against the pipe wall.

Designed to negotiate minimum 3D and greater bends, the XF pig moves reliably through piping systems.

Options Available:

- Circular flange brushes in the following types and trim materials:
 1. Trim types – flat wire or pencil.
 2. Trim material – carbon steel, stainless steel or plastic.
- UT Mandrel to accommodate electronic tracking equipment.
- CARVER discs.
- Aluminum gauge plates in standard styles.
- Magnets can be used to either collect ferrous and other construction debris, or they can be used to provide a change in magnetic field required by non-intrusive pig signaler detection devices.