

MODERATE CLEANING

DC3R

6-14" (152-356mm)

If your pipeline is in need of a good cleaning, the Series DC3R provides efficient cleaning capability.

The DC3R pig features three Series C Cups and two circular brushes. These multiple sealing components create a positive seal between dissimilar fluids, while simultaneously providing a bigger surface area. As a result, its sealing capacity and overall cleaning ability are greatly improved.

When product flows more freely through the pipeline, less energy is required to pump it, reducing production costs. It also reduces maintenance and repair costs down the road. Thanks to Series DCR, it's easy to keep your pipeline debris-free.

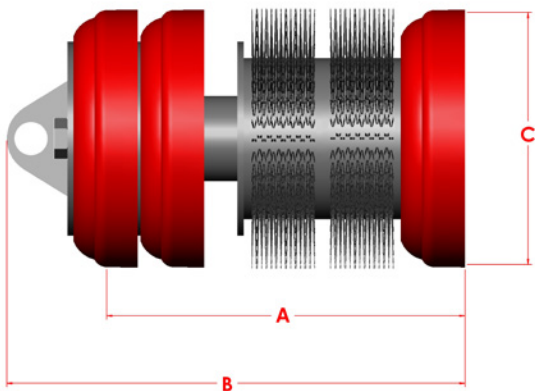

Size	A	B	C	Weight	Part #
6"	9.125	12.375	6.375	18	60-3083-06
8"	12.125	15.500	8.500	32	60-3083-08
10"	15.000	19.125	10.625	53	60-3083-10
12"	16.750	21.250	12.750	77	60-3083-12
14"	18.250	22.875	13.875	89	60-3083-14

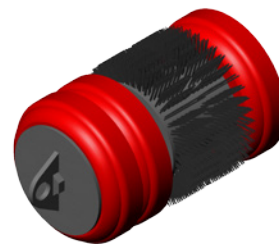

Features & Benefits:

- Every Series DC3R pig is equipped with Apache Series C cups. As with all of Apache products, the Series C cup was specifically developed to perform efficiently and reliably. To enhance durability, it's made from Reliathane, Apache's special blend of wear-resistant polyurethane.
- To use a Series DC3R pig for different applications, elements and brushes can simply be added or reconfigured.

Designed to negotiate minimum 3D and greater bends, the DC3R pig moves reliably through piping systems.

Options Available:

- Circular flange brushes in the following types and trim materials:
 1. Trim types – flat wire or pencil.
 2. Trim material – carbon steel, stainless steel or plastic.
- UT Mandrel to accommodate electronic tracking equipment.
- Aluminum gauge plates in slotted or standard styles.
- Magnets can be used to either collect ferrous and other construction debris, or they can be used to provide a change in magnetic field required by non-intrusive pig signaler detection devices.
- Two (DC2R) and four cup (DC4R) configurations.