

# SCRAPER CUP

## XF

16-48" (406-1219mm)

The Apache XF pig comes standard with a combination of three sealing discs and three Series C cups, providing a positive seal between dissimilar fluids and scraping compability. XF are typically used for longer distance batching operations and for light cleaning of pipelines. Cups and discs can be easily changed or adapted to different configurations as the application dictates.

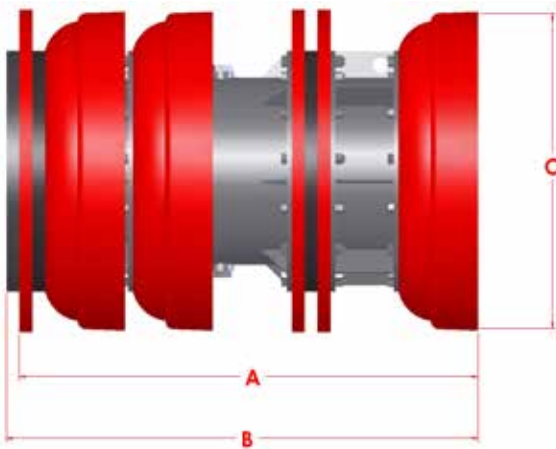

Size	A	B	C	Weight	Part #
16"	23.375	24.375	16.000	140	70678616
18"	27.625	28.625	17.875	174	70678618
20"	30.000	31.000	19.875	231	70678620
22"	32.500	33.500	21.875	267	70678622
24"	35.500	36.500	23.875	359	70678624
30"	45.375	46.500	29.875	541	70678630
36"	53.500	54.875	36.000	823	70678636
42"	62.125	63.625	42.250	1252	70678642
48"	72.000	73.625	47.875	1519	70678648

### Features:

Standard bumper noses prevent damage to both the pig and in-line auxiliary equipment. All Apache 16"-48" pigs are manufactured with by-pass ports. The ports have threaded plugs that can be removed if by-pass is required.

Designed to traverse 3D bends.

### Options:

- Gauging plates of aluminum or steel, and either in slotted or standard styles.
- Transmitter cavity for electronic tracking equipment.
- Magnets are available.
- Circular flat carbon steel, stainless steel, pencil or plastic brushes.