

SCRAPER CUP

DCDX

16-48" (406-1219mm)

The Series DCDX pig come standard with the combination of two cups, two discs and brushes which provides a positive seal between dissimilar fluids and are typically used for long distance operations and light cleaning of pipelines. The increased surface area provided by multiple sealing components significantly improves overall cleaning and sealing capacity of the pig.

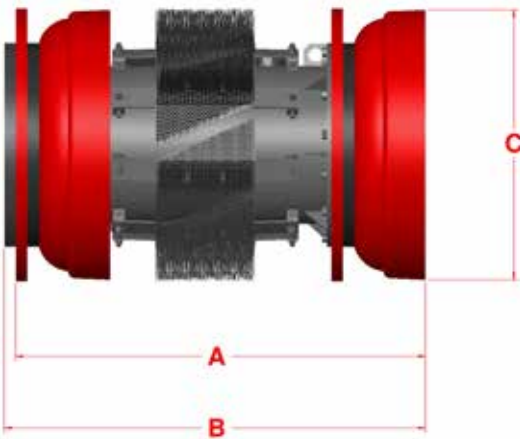

Size	A	B	C	Weight	Part #
16"	24.000	25.000	16.000	132	60370016
20"	30.875	31.875	19.875	212	60370020
22"	33.375	34.375	21.875	246	60370022
24"	35.500	36.500	23.875	307	60370024
30"	42.250	43.375	29.875	459	60370030
36"	49.875	51.250	36.000	682	60370036
42"	57.875	58.750	42.250	999	60370042
48"	62.750	64.500	47.625	1207	60370048

Features:

DCDX pigs are equipped with Apache Series C cups manufactured from high quality Reliathane. The large wear surface of the cup promotes longer life while the product pressure keeps the cutting edge firm against the pipe wall. A standard bumper nose prevent damage to both the pig and in-line auxiliary equipment. All Apache 16"-48" pigs are manufactured with by-pass ports. The ports have threaded plugs that can be removed if by-pass is required.

Designed to traverse 3D bends.

Options:

- Circular flat carbon steel, stainless steel, pencil or plastic brushes.
- Transmitter housing to accommodate electronic tracking equipment.
- Aluminum or steel gauging plates are available in either slotted or standard styles.
- Magnets are available.
- Plow blades.