

SCRAPER CUP

DCD

3-14" (76-356mm)

The Series DCD pig comes standard with a combination of two sealing discs and two Series C Cups, providing a positive seal between dissimilar fluids and scraping capability. The increased surface area provided by multiple sealing components significantly improves overall cleaning and sealing capacity of the pig.

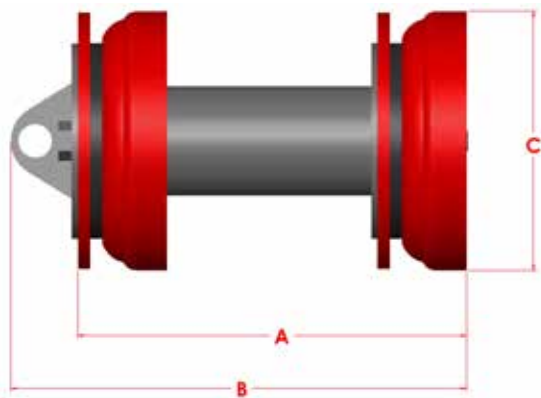

Size	A	B	C	Weight	Part #
3"	4.875	6.500	3.375	2.0	70683003
4"	6.250	8.250	4.375	4.0	70683004
6"	9.375	12.250	6.375	12	70683006
8"	11.875	14.500	8.500	23	70683008
10"	14.875	17.750	10.625	39	70683010
12"	18.125	20.875	12.750	56	70683012
14"	20.750	23.500	13.875	65	70683014

Features:

Configuration of the DCD pig offers a sealing arrangement suitable for separation of dissimilar fluids together with light scraping of pipeline during longer distance operations.

Designed to traverse 1.5D bends.

Options:

- Circular flat carbon steel, stainless steel, pencil or plastic brushes.
- Aluminum or steel gauging plates are available in either slotted or standard styles.
- Magnets are available.
- Available with UT configuration with internal transmitter housing for 6" - 14" pigs.