

SCRAPER CUP

DCD

16-48" (406-1219mm)

The Series DCD pig comes standard with a combination of two sealing discs and two Series C Cups, providing a positive seal between dissimilar fluids and scraping capability. The increased surface area provided by multiple sealing components significantly improves overall cleaning and sealing capacity of the pig.

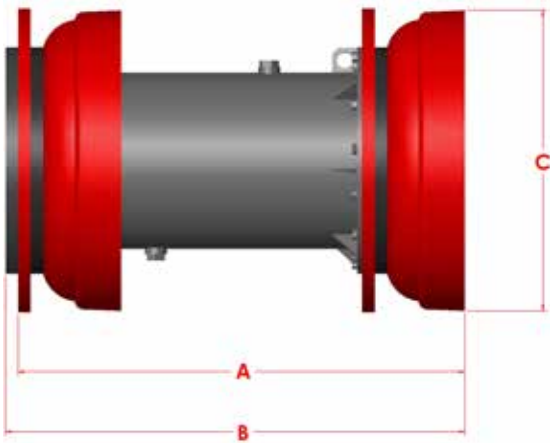

Size	A	B	C	Weight	Part #
16"	23.125	24.125	16.000	97	70683016
20"	28.875	29.875	19.875	159	70683020
22"	31.375	32.375	21.875	183	70683022
24"	34.500	35.500	23.875	234	70683024
30"	42.250	43.375	29.875	376	70683030
36"	49.875	51.250	36.000	583	70683036
42"	57.250	58.750	42.250	865	70683042
48"	62.750	64.500	47.750	1077	70683048

Features:

Configuration of the DCD pig offers a sealing arrangement suitable for separation of dissimilar fluids together with light scraping of pipeline during longer distance operations. Standard bumper noses prevent damage to both the pig and in-line auxiliary equipment. All Apache 16"-48" pigs are manufactured with by-pass ports. The ports have threaded plugs that can be removed if by-pass is required.

Designed to traverse 1.5D bends.

Options:

- Circular flat carbon steel, stainless steel, pencil or plastic brushes.
- Transmitter housing to accommodate electronic tracking equipment.
- Aluminum or steel gauging plates are available in either slotted or standard styles.
- Magnets are available.