

CONICAL CUP

UM3

3-14" (76-356mm)

The basic three cup Series UM pigs are designed for batching of dissimilar fluids and are typically used for longer distance applications. The UM Series are available in three versions. The three cup design of this pig provides a positive seal between fluid interfaces and are widely used for light cleaning of pipelines or batching/separation operations.

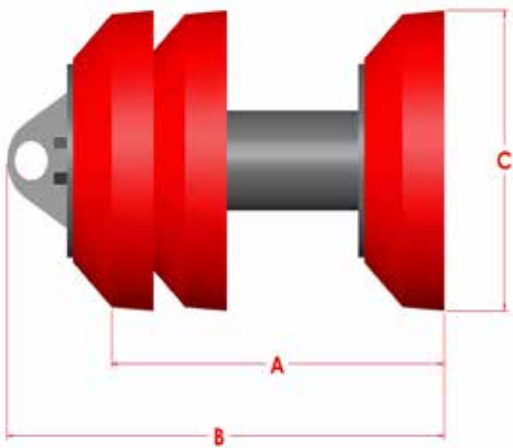

Size	A	B	C	Weight	Part #
3"	4.875	6.750	3.375	3.0	70580303
4"	6.125	8.625	4.375	4.0	70580304
6"	9.250	12.625	6.500	13	70580306
8"	12.000	15.625	8.375	20	70580308
10"	14.875	19.250	10.500	36	70580310
12"	16.625	21.250	12.500	52	70580312
14"	19.500	24.250	14.000	64	70580314

Features:

Configuration of the UM3 pig offers a sealing arrangement suitable for separation of dissimilar fluids together with light scraping of pipeline during longer distance operations. Pipeline pigs mounted with conical cups can traverse pipeline anomalies of up to 20% without damage to inline auxiliary equipment.

Designed to traverse 1.5D bends.

Options:

- Circular flat carbon steel, stainless steel, pencil or plastic brushes.
- Aluminum or steel gauging plates are available in either slotted or standard styles.
- Magnets are available.
- Available with UT configuration with internal transmitter housing for 6" - 14" pigs.