

UTR-EDR

6-12" (152-356mm)

The UT mandrel was designed to house a transmitter located in the center of the slotted universal mandrel. It can also accommodate virtually any configuration of cup, disc and brush. This allows the pig to clean and batch many dissimilar fluids.

The UT-EDR is equipped with sturdy circular flange brushes that forcefully scrub away residue and debris. The UT-EDR provides a moderate cleaning before pipeline testing leaving it ready for assessment. The UT-EDR is also functions as a bidirectional pig.

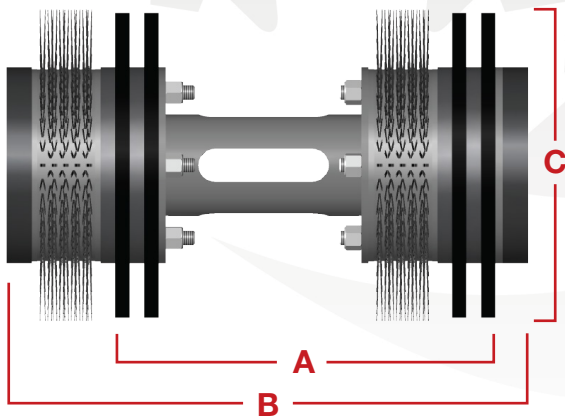

Size	A	B	C	Part #
6"	9.000	12.000	6.375	60-7160-06
8"	11.250	15.375	8.375	60-7160-08
10"	13.125	18.000	10.500	60-7160-10
12"	16.625	22.500	12.500	60-7160-12
14"	18.990	15.865	13.875	60-7160-14

Designed to negotiate 1.5D or greater bends.

Features & Benefits:

- Equipped with discs made from Reliathane, Apache's special blend of wear-resistant polyurethane.
- Standard bumper noses cushion the pig and help to protect in-line auxiliary equipment.

Options Available:

- CARVER discs. See page 5-20 for additional information.
- Aluminum Gauge Plates in standard or slotted styles. See page 6-4 for additional information.
- Radial Brush options available. See page 5-23 for additional information.
- Magnets to collect metallic debris. See page 6-2 for additional information.