

UM2X

16-48" (406-1219mm)

The two-cup design of the UM2X pig provides a positive seal between fluids for efficient batching. In comparison to the UM2, the UM2X includes block brushes to upgrade it to a moderate cleaning pig.

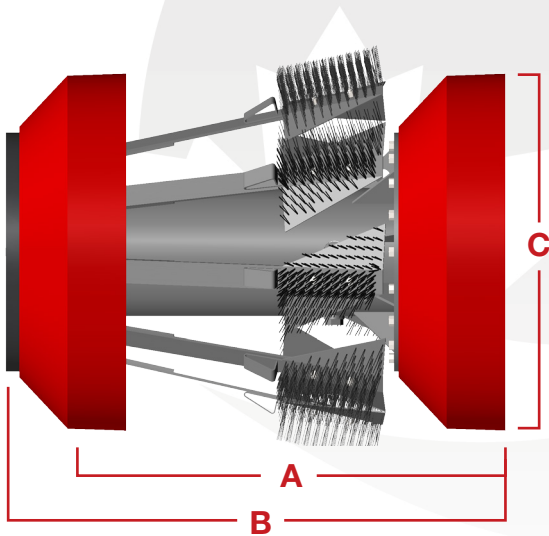

Size	A	B	C	Part #
16"	21.011	24.056	15.875	60-5142-16
20"	26.108	29.437	18.000	60-5142-20
22"	30.055	33.952	22.000	60-5142-22
24"	29.509	33.889	24.000	60-5142-24
30"	36.695	41.854	29.875	60-5142-30
36"	45.782	52.296	36.000	60-5142-36
42"	54.159	61.396	42.000	60-5142-42
48"	60.328	68.668	48.000	60-5142-48

Designed to negotiate 1.5D or greater bends.

Features & Benefits:

- Equipped with two Apache Series M cups made from Reliathane, Apache's special blend of wear-resistant polyurethane.
- The Conical M cup can traverse pipeline anomalies of up to 20% without damaging inline auxiliary equipment.
- Every UM 16" – 48" pig is manufactured with by-pass ports. These ports feature threaded plugs that can be removed.
- Standard bumper noses cushion the pig and help to protect in-line auxiliary equipment.

Options Available:

- CARVER discs. See page 5-20 for additional information.
- Aluminum Gauge Plates in standard styles or slotted styles. See page 6-4 for additional information.
- Radial and Block Brush options available. See pages 5-23 to 5-26 for additional information.
- Magnets to collect metallic debris. See page 6-2 for additional information.
- Transmitter Cavity to accommodate electronic tracking equipment. See page 6-5 for additional information.
- Rattlers. See page 6-5 for additional information.