

UM2

16-48" (406-1219mm)

The two-cup design of the UM2 provides a positive seal between fluids for efficient batching. The UM2 is also capable of providing a light clean to the interior pipe wall.

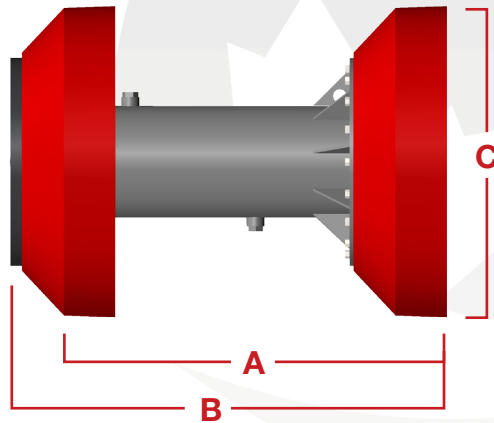

Size	A	B	C	Part #
16"	21.011	24.056	15.875	70-5802-16
20"	25.710	29.320	20.000	70-5802-20
22"	29.180	33.077	22.000	70-5802-22
24"	29.509	33.889	24.000	70-5802-24
30"	36.695	41.854	29.875	70-5802-30
36"	45.782	52.296	36.000	70-5802-36
42"	54.159	61.396	42.000	70-5802-42
48"	60.328	68.668	48.000	70-5802-48

Designed to negotiate 1.5D or greater bends.

Features & Benefits:

- Equipped with two Apache Series M cups made from Reliathane, Apache's special blend of wear-resistant polyurethane.
- The Conical M cup can traverse pipeline anomalies of up to 20% without damaging inline auxiliary equipment.
- Every UM 16" – 48" pig is manufactured with by-pass ports. These ports feature threaded plugs that can be removed.
- Standard bumper noses cushion the pig and help to protect in-line auxiliary equipment.

Options Available:

- CARVER discs. See page 5-20 for additional information.
- Aluminum Gauge Plates in standard styles or slotted styles. See page 6-4 for additional information.
- Radial and Block Brush options available. See pages 5-23 to 5-26 for additional information.
- Magnets to collect metallic debris. See page 6-2 for additional information.
- Transmitter Cavity to accommodate electronic tracking equipment. See page 6-5 for additional information.
- Rattlers. See page 6-5 for additional information.