

UT-DCD

6-14" (152-356mm)

The UT mandrel was designed to house a transmitter located in the center of the slotted universal mandrel. It can also accommodate virtually any configuration of cup, disc and brush. This allows the pig to clean and batch many dissimilar fluids.

The UT-DCD is an effective pig for batching and separating. The UT-DCD is equipped with two sealing discs and two Series C cups. These multiple sealing components create a positive seal between dissimilar fluids, while providing a larger sealing surface area.

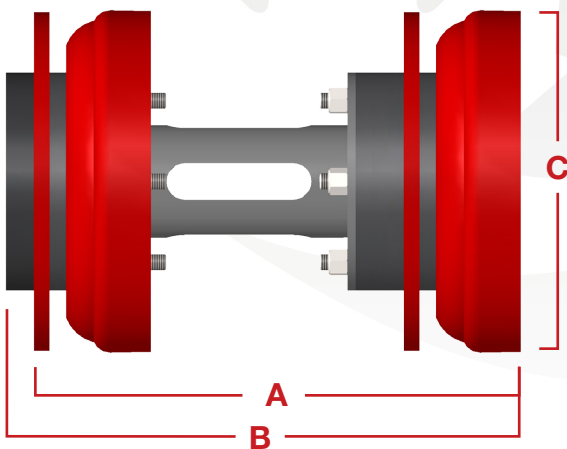

Size	A	B	C	Part #
6"	10.690	11.440	6.375	70-6840-06
8"	13.280	14.030	8.500	70-6840-08
10"	15.150	16.020	10.625	70-6840-10
12"	18.700	19.570	12.750	70-6840-12
14"	21.690	22.570	13.880	70-6840-14

Designed to negotiate 1.5D or greater bends.

Features & Benefits:

- Equipped with Series C cups and discs made from Reliathane, Apache's special blend of wear-resistant polyurethane.
- Large wearing surface of the cup promotes longer life while the edge holds firmly against the pipe wall.
- Standard bumper noses cushion the pig and help to protect in-line auxiliary equipment.

Options Available:

- CARVER discs. See page 5-20 for additional information.
- Aluminum Gauge Plates in standard or slotted styles. See page 6-4 for additional information.
- Radial Brush options available. See page 5-23 for additional information.
- Magnets to collect metallic debris. See page 6-2 for additional information.