

## UT-UC2

6-14" (152-356mm)

The UT mandrel was designed to house a transmitter located in the center of the slotted universal mandrel. It can also accommodate virtually any configuration of cup, disc and brush. This allows the pig to clean and batch many dissimilar fluids.

The UT-UC2 is typically used in light cleaning during the construction phase. However, it can be used in all phases of pipeline cleaning. The UT-UC2 is equipped with two Series C cups specifically designed to perform efficiently and reliably.

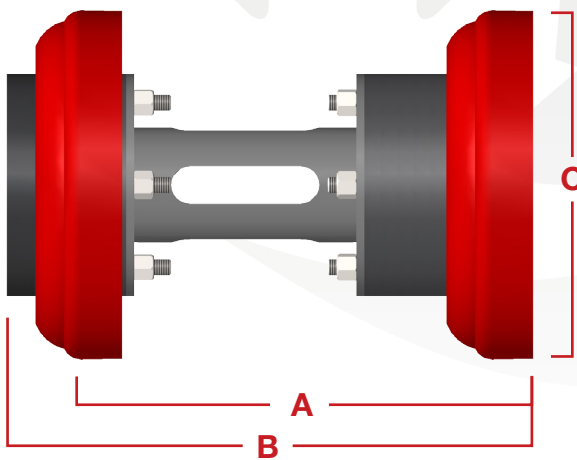

| Size | A      | B      | C      | Part #     |
|------|--------|--------|--------|------------|
| 6"   | 9.880  | 11.440 | 6.375  | 70-3812-06 |
| 8"   | 12.260 | 14.030 | 8.500  | 70-3812-08 |
| 10"  | 14.110 | 16.020 | 10.625 | 70-3812-10 |
| 12"  | 17.280 | 19.570 | 12.750 | 70-3812-12 |
| 14"  | 19.920 | 22.570 | 13.880 | 70-3812-14 |

Designed to negotiate 1.5D or greater bends.

### Features & Benefits:

- Equipped with Series C cups made from Reliathane, Apache's special blend of wear-resistant polyurethane.
- Large wearing surface of the cup promotes longer life while the edge holds firmly against the pipe wall.
- Standard bumper noses cushion the pig and help to protect in-line auxiliary equipment.

### Options Available:

- CARVER discs. See page 5-20 for additional information.
- Aluminum Gauge Plates in standard or slotted styles. See page 6-4 for additional information.
- Radial Brush options available. See page 5-23 for additional information.
- Magnets to collect metallic debris. See page 6-2 for additional information.