

## XF

16-48" (406-1219mm)

The XF is primarily used for batching dissimilar fluid. With its standard three cup – three sealing disc design, the XF pig provides a positive seal between fluids for efficient batching and separating. It is typically used for longer distance operations.

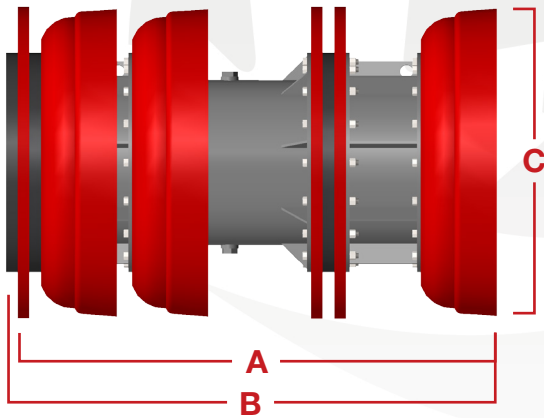

Size	A	B	C	Part #
16"	24.300	25.300	16.000	70-6786-16
18"	27.528	28.528	17.875	70-6786-18
20"	30.015	31.015	19.875	70-6786-20
22"	31.525	32.525	21.875	70-6786-22
24"	35.454	36.454	23.875	70-6786-24
26"	36.119	37.119	25.875	70-6786-26
28"	44.075	45.200	28.000	70-6786-28
30"	46.406	47.531	29.875	70-6786-30
32"	54.190	55.440	32.000	70-6786-32
34"	54.360	55.610	34.000	70-6786-34
36"	56.514	57.889	36.000	70-6786-36
42"	62.170	63.670	42.190	70-6786-42
48"	71.934	73.684	47.750	70-6786-48

Designed to negotiate 3D or greater bends.

### Features & Benefits:

- Equipped with Series C cups and discs made from Reliathane, Apache's special blend of wear-resistant polyurethane.
- Large wearing surface of the cup promotes longer life while the edge holds firmly against the pipe wall.
- Every XF 16" – 48" pig is manufactured with by-pass ports. These ports feature threaded plugs that can be removed.
- Standard bumper noses cushion the pig and help to protect in-line auxiliary equipment.

### Options Available:

- CARVER discs. See page 5-20 for additional information.
- Aluminum Gauge Plates in standard styles or slotted styles. See page 6-4 for additional information.
- Radial and Block Brush options available. See pages 5-23 to 5-26 for additional information.
- Magnets to collect metallic debris. See page 6-2 for additional information.
- Transmitter Cavity to accommodate electronic tracking equipment. See page 6-5 for additional information.
- Rattlers. See page 6-5 for additional information.